

# 3M-Matic™ Adjustable Case Sealer 7000a/7000a3 with AccuGlide™ 2+ Taping Head

## Consistent. Reliable. Tough.

Today, companies need to be fast and flexible in every phase of their operations—and that includes end-of-line packaging. The 3M-Matic™ Adjustable Case Sealer 7000a/7000a3 gives manufacturers and distributors from every industry the packaging flexibility and speed to stay one step ahead of the competition.

3M™ AccuGlide™ 2+ Taping Head Technology and tough, durable construction make sure your boxes are sealed swiftly and reliably, shift after shift, year after year. Plus, expanded box size capacity and interchangeable 2-inch or 3-inch taping heads allow you to change as your business changes, boosting your productivity, cutting your costs and keeping your business nimble.



### Operating Rate

Seals up to 30 cases per minute

### Box Capacities

**Length:** 6.0" to unlimited

**Width:** 6.5" to 22"

**Height:** 3.5" to 24.5" (standard)  
7.0" to 29.5" (high)



# 3M-Matic™ Adjustable Case Sealer 7000a/7000a3

## Innovative Features

- 3M™ AccuGlide™ 2+ Taping Heads ensure reliable application of tape without box damage
- Auxiliary offset taping head position increases flexibility in sealing shorter boxes
- Interchangeable 2- or 3-inch taping heads maximize production flexibility
- Easily accessible side handle and reference ruler make height adjustments a snap for a wide variety of case heights from 3.5–29.5 inches
- Rugged, dual-extruded columns allow for smooth incremental adjustments to case heights

## Standard Features

- Top and bottom drive belt system
- Top flap compression rollers
- Centrally located emergency stop
- Spring-loaded upper drive assembly
- Dual masts and dual lead screws

**Options:** Infeed and exit conveyors, locking casters, low tape indicator, tape application monitor, box hold-down attachment

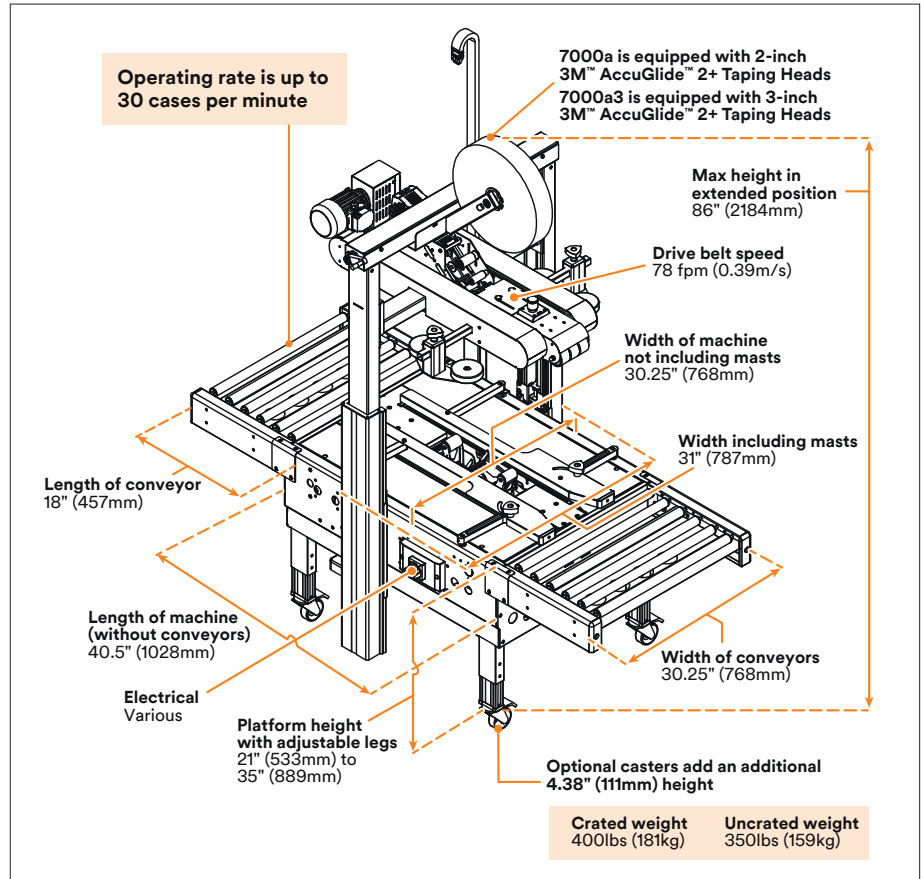

## Box Capacities

Machine	Length		Width		Height*	
	Minimum** in. (mm)	Maximum*** in. (mm)	Minimum** in. (mm)	Maximum*** in. (mm)	Maximum** in. (mm)	Maximum*** in. (mm)
7000a/ 7000a3	6.0 (152)	N/L	6.5 (165)	22 (559)	4.75 (121)	28.5 (724)

\*Requires a column adjustment for case heights lower than 4.25" or higher than 28".

\*\*Minimum case height of 1.5" requires LHB taping heads in 1-3/8" tape leg position, 78 fpm belt speed.

\*\*\*Maximum case height of 28.5" can be obtained by moving the columns and the upper assembly to the upper mast position. Minimum will be 12.75".

Contact your 3M representative for special modifications that may be available for sizes not listed.

**Note:** This technical information and data should be considered representative or typical only and should not be used for specification purposes.

## Visit [3M.com/packaging](http://3M.com/packaging) for more information



3M Industrial Adhesives and Tapes Division  
3M Center, Building 225-3S-06  
St. Paul, MN 55144-1000

Phone 800-362-3550  
Web [3M.com/packaging](http://3M.com/packaging)

**Product Use:** Many factors beyond 3M's control and uniquely within user's knowledge and control can affect the use and performance of a 3M product in a particular application. Given the variety of factors that can affect the use and performance of a 3M product, user is solely responsible for evaluating the 3M product and determining whether it is fit for a particular purpose and suitable for user's method of application. **Warranty, Limited Remedy, and Disclaimer:** Unless an additional warranty is specifically stated on the applicable 3M product packaging or product literature, 3M warrants that each 3M product meets the applicable 3M product specification at the time 3M ships the product. 3M MAKES NO OTHER WARRANTIES OR CONDITIONS, EXPRESS OR IMPLIED, INCLUDING, BUT NOT LIMITED TO, ANY IMPLIED WARRANTY OR CONDITION OF MERCHANTABILITY OR FITNESS FOR A PARTICULAR PURPOSE OR ANY IMPLIED WARRANTY OR CONDITION ARISING OUT OF A COURSE OF DEALING, CUSTOM OR USAGE OF TRADE. If the 3M product does not conform to this warranty, then the sole and exclusive remedy is, at 3M's option, replacement of the 3M product or refund of the purchase price. **Limitation of Liability:** Except where prohibited by law, 3M will not be liable for any loss or damage arising from the 3M product, whether direct, indirect, special, incidental or consequential, regardless of the legal theory asserted, including warranty, contract, negligence or strict liability.

3M, 3M-Matic and AccuGlide are trademarks of 3M Company.  
Please recycle. Printed in USA. © 3M 2016. All rights reserved. E-70-0710-0476-9