

Instructions and Parts List

3M-Matic™

7000r-I / 7000r3-I Pro

Type 11700

Random Case Sealer

AccuGlide™ 3

Taping Heads

Serial #: _____
For reference, record machine serial number here.

Important Safety Information

BEFORE INSTALLING OR OPERATING THIS EQUIPMENT
Read, understand and follow all safety and operating instructions.

Spare Parts

It is recommended you immediately order the spare parts listed in the “Spare Parts/Service Information” section. These parts are expected to wear through normal use, and should be kept on hand to minimize production delays.

1. Introduction

1.1 Manufacturing Specifications / Description / Directives / Intended Use

The **3M-Matic™ 7000r-I / 7000r3-I Pro Random Case Sealer with AccuGlide™ 3 Taping Heads** is designed to apply a “C” clip of **Scotch®** pressure-sensitive film box sealing tape to the top and bottom center seam of regular slotted containers. The **7000r-I / 7000r3-I Pro** automatically adjusts to a wide range of box sizes (see “Specifications Section – Box Weight and Size Capacities”). The **3M-Matic™** case sealing machines have been designed and manufactured in compliance with the legal requirements at the date of inception.

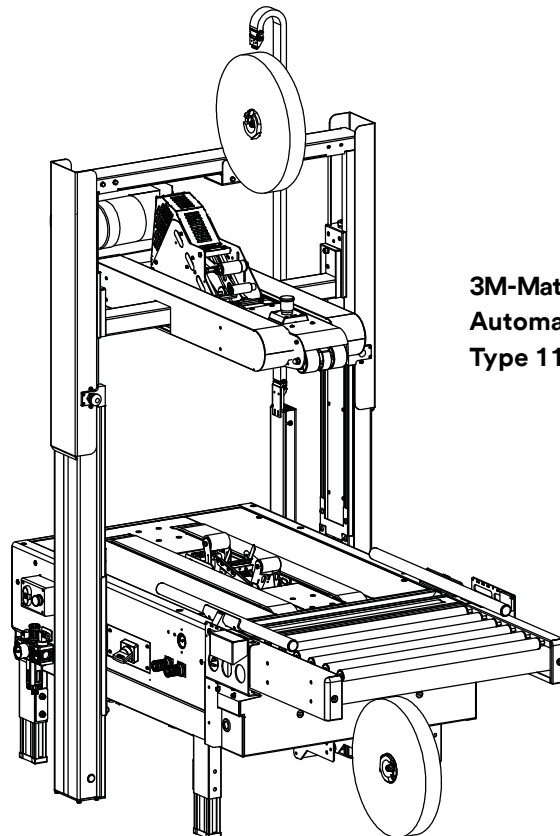

**3M-Matic™ 7000r-I / 7000r3-I Pro
Automatic Case Sealer
Type 11700**

The **3M-Matic™** case sealing machines have been designed and manufactured following the Machinery Directive: 2006/42/EC, EMC Directive: 2014/30/EU, RoHS Directive: 2011/65/EU in compliance with the legal requirements at the date of inception.

Reference Documents - Safety:

EN ISO 12100	Safety of machinery. General principles for design. Risk assessment and risk reduction
EN 60204 1	Safety of machinery. Electrical equipment of machines. General requirements
EN ISO 13849 1	Safety of machinery. Safety related parts of control systems. Part 1. General principles for design
EN ISO 11202	Acoustics — Noise emitted by machinery and equipment. Determination of emission sound pressure levels at a work station and at other specified positions – w/corrections
EMC:	
EN 61000 6 2	Electromagnetic compatibility (EMC). Generic standards. Immunity standard for industrial environments
EN 61000 6 4	Electromagnetic compatibility (EMC). Generic standards. Emission standard for industrial environments

3. Safety (continued)

3.12 Component Locations

Refer to **Figure 3-9** below to acquaint yourself with the various components and controls of the case sealer. Also refer to Manual 2 or 3 for taping head components.

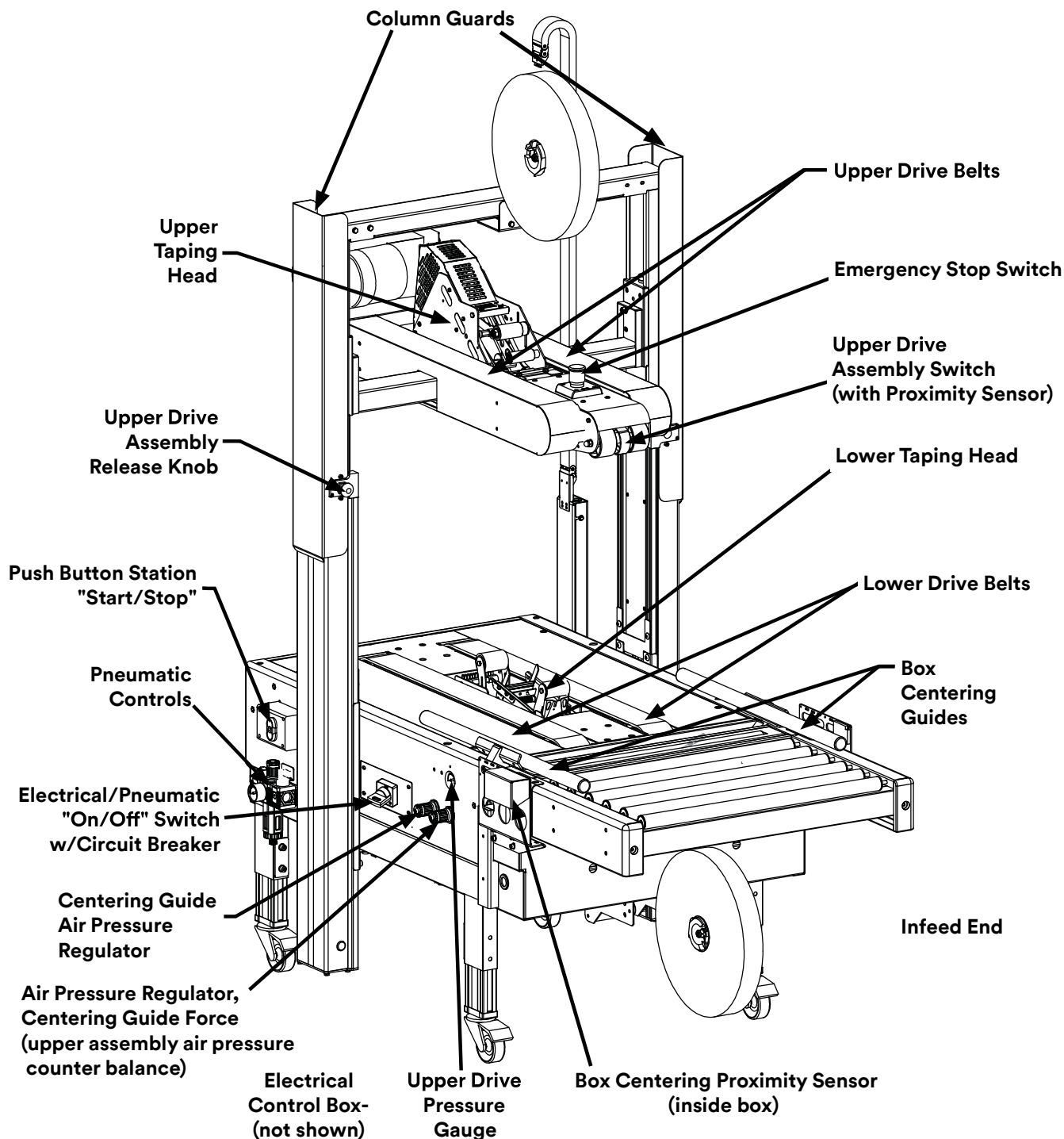

Figure 3-9: 7000r-I / 7000r3-I Pro Case Sealer Components (Left Front View)

3. Safety (continued)

3.13 Table of Warnings and Replacements Labels

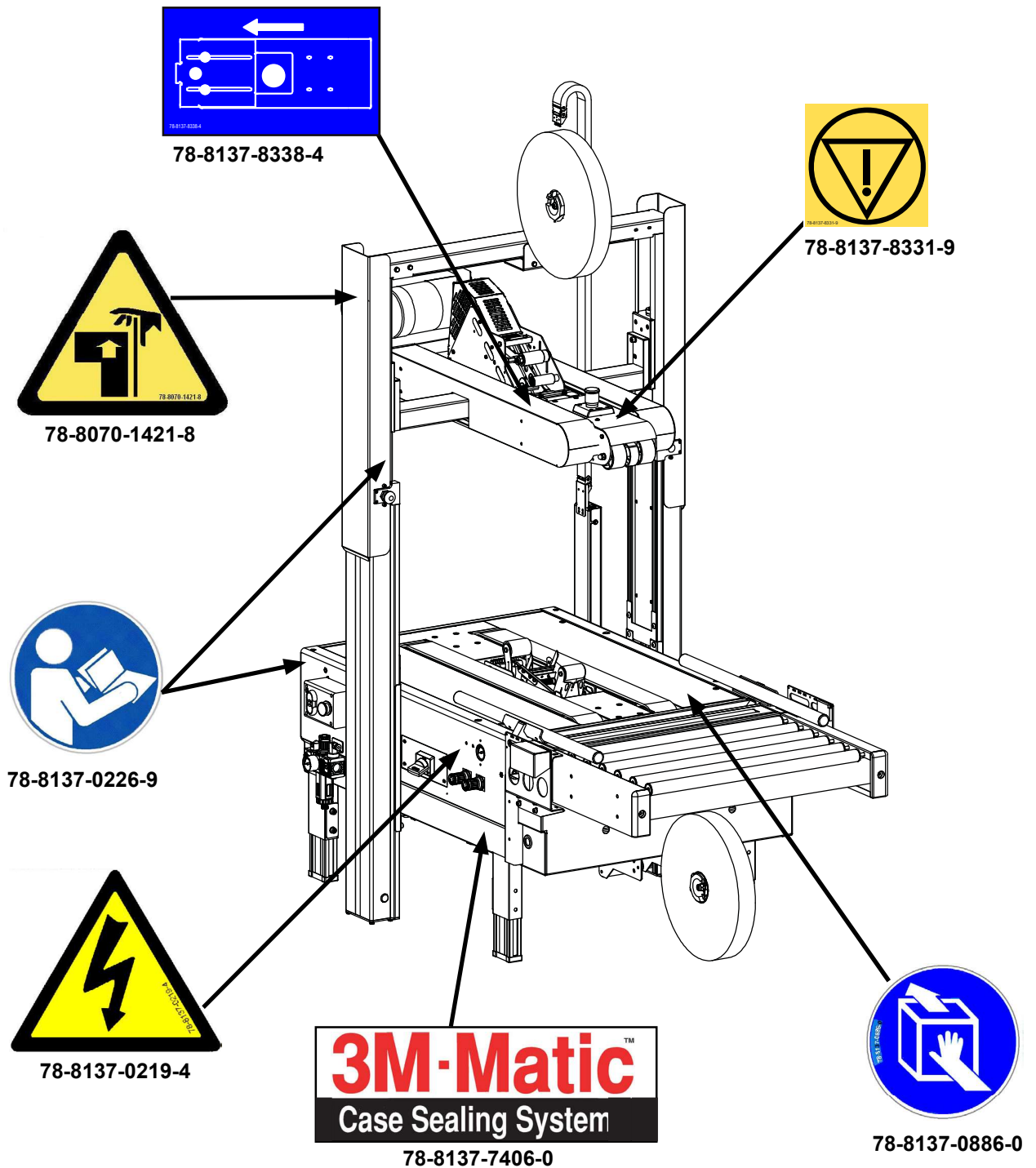

Figure 3-10: Replacement Labels / 3M Part Numbers

3. Safety (continued)

3.13 Table of Warnings and Replacements Labels (continued)

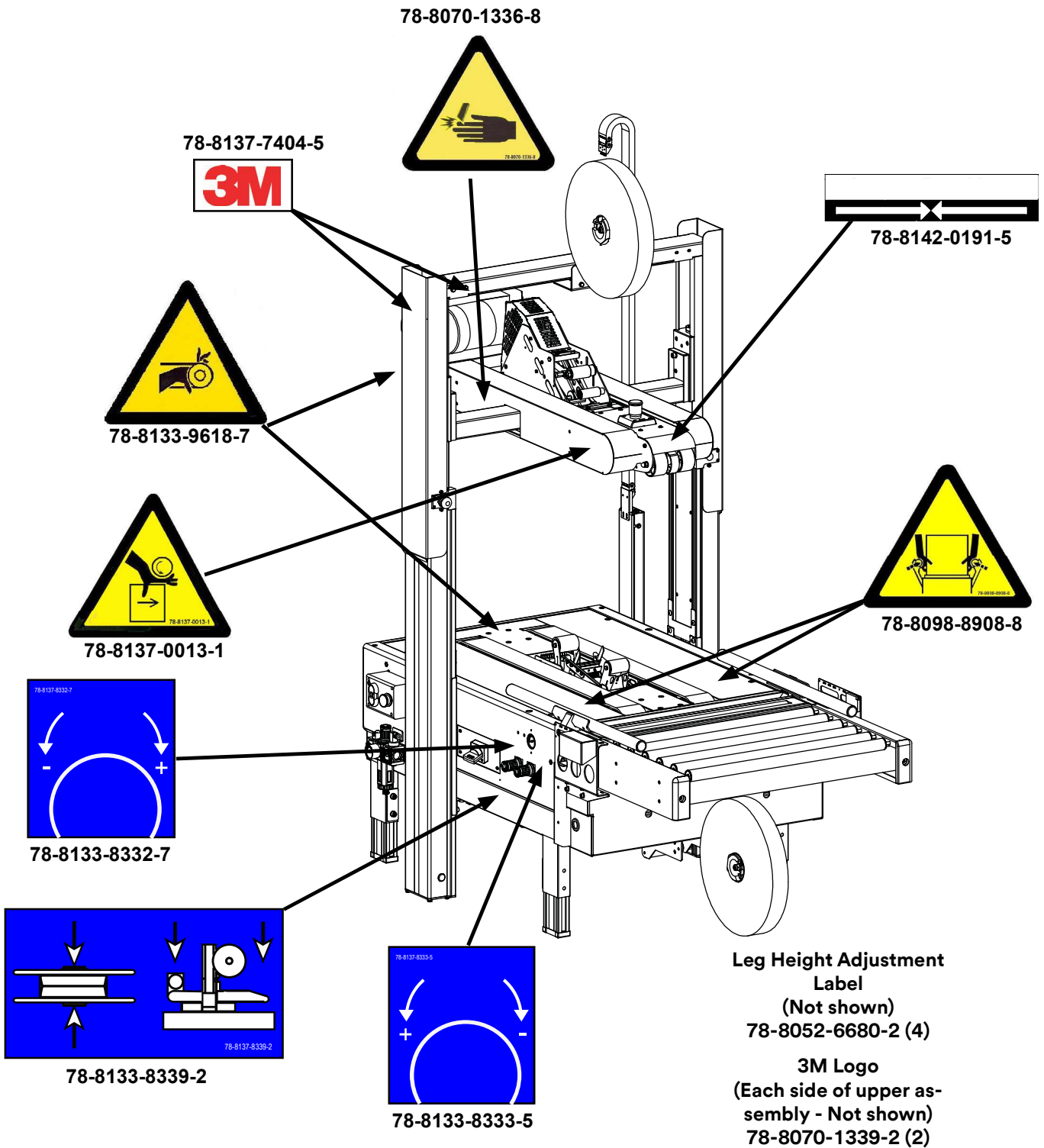

Figure 3-11: Replacement Labels / 3M Part Numbers

4. Specifications

4.1 Power Requirements:

Electrical – 230/400 Volt, 50 Hz., SCCR: 5kA

Pneumatic: 90PSIG [6.2 bar], 11.6 SCFM [1200 NL/Min] Peak Usage.

The machine is equipped with a 2.4m [8 foot] standard neoprene covered power cord. Contact your 3M Representative for power requirements not listed above.

4.2 Operating Rate: Belt speed is 0.5m/s [100 F.P.M.]

Actual production rate is dependent on operator's dexterity.

Boxes must be 18 inches (457mm) apart minimum.

4.3 Operating Conditions

Ingress protection: IP4X. Use in an indoor dry, relatively clean environment, 50% Relative Humidity, 5° C to 40° C [40° F to 104° F], maximum elevation of 1000 meters (3281 ft) with clean, dry boxes.

Note: Machine should not be washed or subjected to conditions causing moisture condensation on components.

	Warning
<ul style="list-style-type: none">• To reduce the risk associated with fire and explosion hazards:<ul style="list-style-type: none">- Do not operate this equipment in potentially flammable or explosive environments.	

4.4 Machine Noise Level (measured at workplace):	Under Load	Idling
Weighted emission sound pressure level/workplace	81,2db	68.0db
Uncertainty	3db	3db
A-Weighted sound power level	92,6db	79,4db
Uncertainty	3db	3db

The use of hearing protection is recommended

Note: Noise levels will vary and are dependant on the pressure sensitive tape used in the application. The sum of measured value of noise plus its associated uncertainty represents an upper limit of range of values. Idling refers to machine running in rest position (no boxes). Under Load refers to machine running and box taping using adhesive tape 3M-Scotch 75mm (3") AccuGlide - Bottom Taping Head.

4. Specifications *(continued)*

4.5 Tape - Scotch® pressure-sensitive film box sealing tapes.

4.6 Tape Width

50mm [2 inches] minimum to 72mm [3 inches] maximum.

4.7 Tape Roll Diameter

Up to 405mm [16 inch] maximum on a 76.2mm [3 inch] diameter core.
(Accommodates all system roll lengths of **Scotch®** film tapes)

4.8 Tape Width - Standard

70mm ± 6 mm [2.75 inch ± 0.25 inch]

Tape Application Leg Length – Optional

50mm ± 6mm [2 inch ± 0.25 inch]

(See “Removing Taping Heads Procedure – Changing the Tape Leg Length”)

4.9 Box Board

Style – regular slotted containers – RSC.

125 to 275 P.S.I. bursting test, single wall or double wall B or C flute.

23-44 lbs. per inch of width Edge Crush Test (ECT).

4.10 Box Weight and Size Capacities

A. Box Weight, filled: 5 lbs.– 85 lbs. [2.3 kg–38.6 kg]. Contents must support flaps.

B. Box Dimensions for **7000r-1/7000r3-1 Pro** Machines: Inches [mm]

* Boxes narrower than 8 inches [200mm] may require more frequent belt replacement because of limited contact area.

To accommodate smaller or larger boxes, machine upper taping head frame and/or outer column assemblies can be repositioned as described in “Special Set-Up Procedure” section of this manual. Refer to illustration/chart for box height range possibilities by adjusting machine upper frame and/or outer column positioning.

	Length	Width	(A) Standard Pos. AG 3 Tape Leg (i.e. 2.75" [70])	(B) Fully Raised Pos.	(C) Lowered Pos. Tape Leg 2" [50] (AG3/no bumper)
Minimum	6" [152]	6.5" [165]*	4.5" [115]	12.5" [317]	2.25" [57]
Maximum	N/A	26" [660]	26" [660]	36" [914]	25.5" [647]

4. Specifications (continued)

Minimum/Maximum Box Height Combinations (To relocate upper frame or outer columns, see "Special Set-Up Procedure")

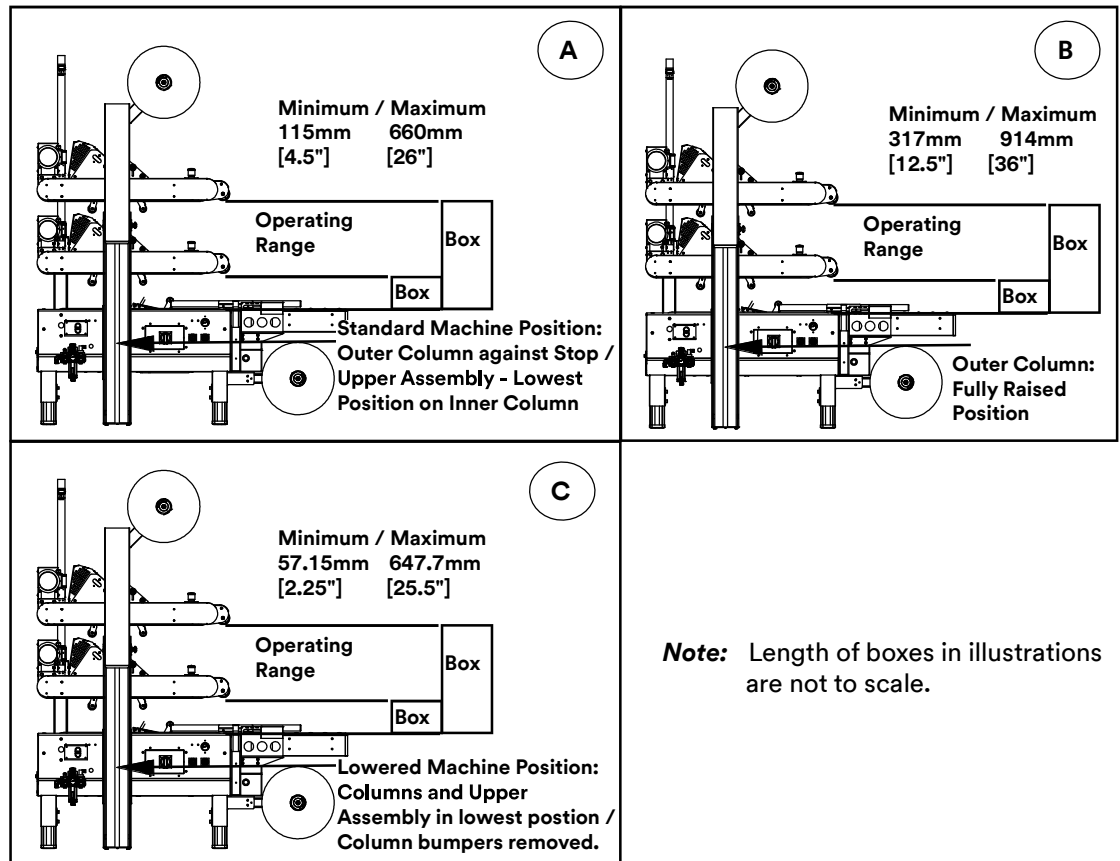

Case Height Range Illustration:

- A. Standard Machine Position:** Outer Columns positioned against Stop with Upper Drive Assembly set to Lowest Position on Inner Columns. Tape Leg Length - 2.75" [70mm].
- B. Raised Machine Position:** Maximum Box Height (i.e. Outer Columns and Upper Drive Assembly in Highest Position - See Special Set-Up Procedure). Tape Leg Length - 2.75" [70mm].
- C. Lowered Machine Position:** Lowest Box Height, columns in lowest position heads in offset position, Tape leg length 2", Upper assembly in lowest position, column bumpers removed.

Boxes narrower than 8" [200mm] may require more frequent belt replacement because of limited contact area.

Special modifications may be available for carton sizes not listed on previous page. Contact your 3M Representative for information.

Note: The case sealer can accommodate most boxes within the size range listed above. However, if the box length (in direction of seal) to box height ratio is .6 or less, then several boxes should be test run to assure proper machine performance. Any box ratio approaching this limitation should be test run to assure performance.

DETERMINE THE BOX LIMITATIONS BY COMPLETING THIS FORMULA:

BOX LENGTH IN DIRECTION OF SEAL = SHOULD BE GREATER THAN .6
BOX HEIGHT

4. Specifications *(continued)*

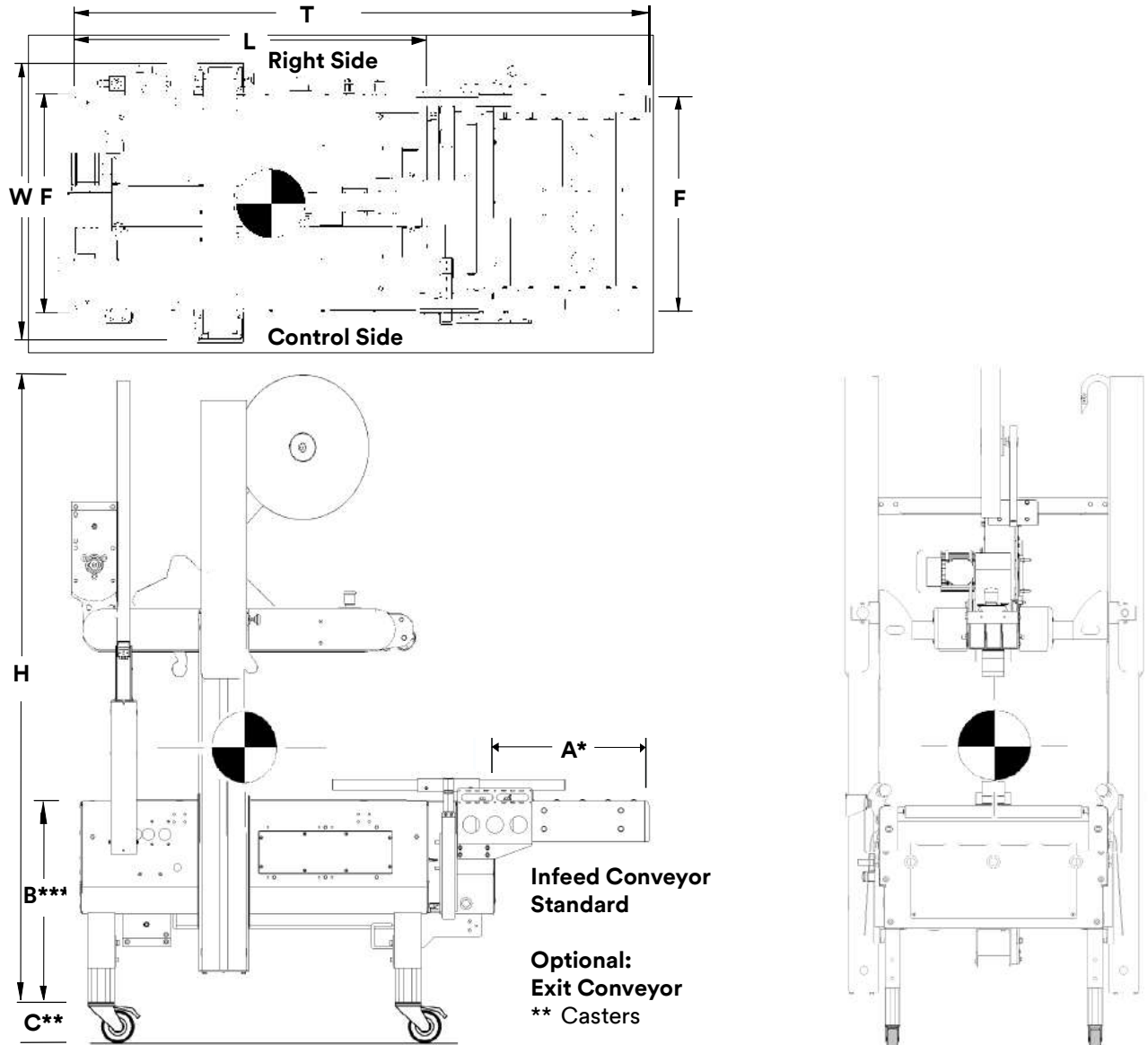

4.11 Machine Dimensions:

	W	L	H	A	B	C	F	T
Minimum								
mm	959	1180	1575	457	597***	111	768	1637
[Inches]	[37.6]	[46.5]	[62]	[18]	[23.5]	[4.38]	[30.3]	[64.25]
Maximum								
mm	--	--	2642	--	890	--	--	-
[Inches]	--	--	[104]	--	[35]	--	--	-

***Column Repositioning Required

Packaged:

49.5" [1257] (H)X51" [1295] (L)X42" [1067] (W)

Weight: 225 kg [500 pounds] crated (approximate)
200 kg [430 pounds] uncrated (approximate)

4.12 Set-Up Recommendations:

(Note: Powered exit conveyor should match belt speed of case sealer - 100 fpm)

- Machine must be level.
- Observe Center of Gravity when lifting and moving machine.
- Avoid floor with greater than 10 degree slope.
- Supplied infeed and optional exit conveyors (if used) should provide straight and level box entry/exit.
- Optional exit conveyor (powered or gravity) can help move sealed boxes away from machine.

